



*C/ Narcís Monturiol, 34
08192 Sant Quirze del Vallès
BARCELONA
TEL. 93 714-49-24
ventas@kartsana.com
www.kartsana.com*

INSTRUCTIONS MANUAL

COMPACT STRETCHER SERIE TGE-241

Models TGE-241-M, TGE-241-XL



*Please read the instruction manual before
usage and keep them for future reference.*





acondicionamiento para hospitales y ambulancias

OPERATION AND HANDLING OF THE TGE-241 SERIES

CONTENTS

1.- INTRODUCTION	3
1.1.- FOREWORD	3
1.2.- RESPONSIBILITY AND WARRANTY	3
1.3.- SPECIFICATIONS	3
1.4.- ATTENTION	4
1.5.- SUMMARY OF SAFETY PRECAUTIONS	4
2.- INSTRUCTIONS MANUAL	6
2.1.- TECHNICAL SPECIFICATIONS	6
2.1.1.- TECHNICAL SPECIFICATIONS TGE-241-M / XL	6
2.2.- OPERATING AND HANDLING THE STRETCHER	7
2.2.1.- REMOVABLE CUFFS	7
2.2.2.- ADJUSTABLE RECLINING HEAD	7
2.2.3.- SAFETY RAIL	8
2.2.4.- INTRAVENOUS DRIP STAND	8
2.2.5.- METHOD FOR FASTENING THE SAFETY BELTS ON THE PATIENT'S HEAD AND FEET	10
2.2.6.- METHOD FOR FASTENING THE SAFETY BELT ON THE PATIENT'S	10
2.2.7.- DISMANTLING-ASSEMBLING THE STRETCHER SAFETY BELTS	11
2.2.8.- CONTROL FOR OPERATING THE STRETCHER LEGS	13
2.2.9.- INTERMEDIATE POSITIONS OF THE STRETCHER	14
2.2.10.- BRAKE LEVER	17
2.2.11.- LOCK/UNLOCK WHEELS	17
2.2.12.- MOUNTING THE STRETCHER ON THE AMBULANCE STRETCHER HOLDER	18
3.- DESINFECTION	19
4.- MAINTENANCE	19
5.- EXPLODED VIEWS	20
5.1.- TGE-241-M	20
5.2.- TGE-241-XL	23

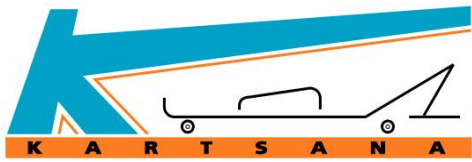

acondicionamiento para hospitales y ambulancias

OPERATION AND HANDLING OF THE TGE-241 SERIES

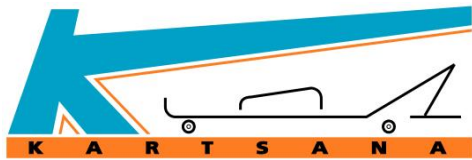

acondicionamiento para hospitales y ambulancias

OPERATION AND HANDLING OF THE TGE-241 SERIES

1.- INTRODUCTION

1.1.- Foreword

TGE-241 series is specially designed for the rescue and transportations of patients.

TGE-241 series is and has been tested in accordance with the UNE-EN 1865 and UNE-EN 1789 standards.

All the information regarding treatment, disinfection and maintenance is indicated, taking into consideration our current experience and know-how.

Certain technical modifications to the stretcher have been placed under reserve for the purpose of making improvements to the product.

We reserve the right to change the specifications of the stretcher to improve the products.

1.2.- Responsibility and warranty

The stretcher must be checked at the time of its delivery to the assistance organisation. All its functions must be explained in great detail. The assistance organisation must take charge of teaching all its employees how to use it correctly.

The product has a warranty of 24 months from the date of delivery to the end user.

The warranty will not cover the fault if that fault is due to incorrect installation, mistreatment or improper use of the stretcher. All repairs must be made by a technical service authorised by Kartsana or its respective representative.

The manufacture will not be responsible for any anomaly caused to the stretcher due to using any products other than original Kartsana products.

1.3.- Specifications

MODELS	TGE-241-M	TGE-241-XL
Maximum load	250 Kg*	250 Kg*
Standards	UNE-EN-1865-1 EN-1789+A1	UNE-EN-1865-1 EN-1789+A1
Total length (non-extended / extended)	1951/ 2250 mm	1952/ 2251 mm
Total Width	568 mm	568 mm
Loading Height	590 mm	685 mm
Weight	36,5 Kg	38 Kg
Minimum operators required for an occupied / unoccupied stretcher	2 / 1	2 / 1
Compatible fixation systems	R-419 / R-450 -S / R-800 and R-900	R-419 / R-450 -S / R-800 and R-900

*Stretcher not valid for bariatric or pediatric transport.



acondicionamiento para hospitales y ambulancias

OPERATION AND HANDLING OF THE TGE-241 SERIES

1.4.- Attention



Through this sign, information is furnished on important safety measures for the correct use of the stretcher, in order to prevent accidents. The **warnings** alerts the reader about a situation which, if not avoided, could result in death or serious injury. The **cautions** alerts the reader of a potentially hazardous situation which, if not avoided, may result in minor or moderate injury to the user or patient or damage to the equipment or other property. This includes special care necessary for the safe and effective use of the device and the care necessary to avoid damage to a device that may occur as a result of use or misuse.

1.5.- Summary of safety precautions

Carefully read and strictly follow the warnings and cautions listed on these pages. Service only by qualified personnel.



WARNINGS:

- Improper usage of the stretcher can cause injury to the patient or operator. Operate the stretcher only as described in this manual.
- Do not modify the stretcher or any components of the stretcher. Modifying the product can cause unpredictable operation resulting in injury to the patient or operator. Modifying the product also voids its warranty.
- Any emergency vehicle to be used with this stretcher must have the compatible fixation system installed.
- Have the vehicle safety rail compatible installed by a certified mechanic. Improper rail installation can cause injury to the patient or operator and/or damage to the stretcher. Verify that the stretcher legs lock into the load position before without contact with the fender of the vehicle. Failure to properly lock the stretcher height into position can cause injury to the patient or operator and/or damage to the stretcher
- Practice changing height positions and loading the stretcher until operation of the product is fully understood. Improper use can cause injury.
- Do not allow untrained assistants to assist in the operation of the stretcher. Untrained technicians/assistants can cause injury to the patient or themselves.
- Grasping the stretcher improperly can cause injury. Keep hands, fingers and feet away from moving parts. To avoid injury, use extreme caution when placing your hands and feet near the base tubes while raising and lowering the stretcher.
- Always use all restraint straps to secure the patient on the stretcher. An unrestrained patient may fall from the stretcher and be injured.
- Never leave a patient unattended on the stretcher or injury could result. Hold the stretcher securely while a patient is on the product.
- Side rails are not intended to serve as a patient restraint device.
- High obstacles such as curbing, steps or rough terrain can cause the stretcher to tip, possibly causing injury to the patient or operator.
- TGE-241 series is designed to be compatible with Kartsana models R-419 / R-450 -S / R-800 and R-900, and is operator responsibility that these products work together.
- Two operators must be present when the stretcher is occupied.
- Operators must be able to lift the total weight of the patient, stretcher and any items on the stretcher.
- Never install or use a wheel lock on a stretcher with excessively worn wheels. Installing or using a wheel lock on a wheel with less than a 200mm diameter could compromise the holding ability of the wheel lock, possibly resulting in injury to the patient or operator and/or damage to the stretcher or other equipment.
- When cleaning, use any appropriate personal safety equipment (goggles, respirator, etc.) to avoid the risk of inhaling contagion.
- Some cleaning products are corrosive in nature and may cause damage to the product if used improperly. If the products described above are used to clean Kartsana equipment, measures must be taken to ensure the stretchers are wiped with clean

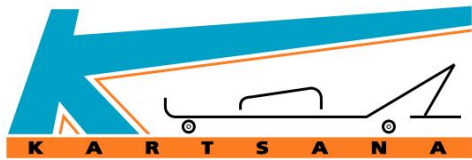

acondicionamiento para hospitales y ambulancias

OPERATION AND HANDLING OF THE TGE-241 SERIES

water and thoroughly dried following cleaning. Failure to properly rinse and dry the stretchers will leave a corrosive residue on the surface of the stretchers, possibly causing premature corrosion of critical components.

- Failure to properly clean or dispose of contaminated mattress or other stretcher components will increase the risk of bloodborne pathogens and may cause injury to the patient or operator.



CAUTIONS:

- Changes or modifications to the unit not expressly approved by Kartsana could void the user's authority to operate the system.
- Installation of the safety hook should be done by a certified mechanic familiar with ambulance vehicle construction. Consult the vehicle manufacturer before installing the safety hook and be sure that the installation of the safety hook does not damage or interfere with the brake lines, oxygen lines, fuel lines, fuel tank or electrical wiring of the vehicle.
- Before operating the stretcher, clear any obstacles that may interfere and cause injury to the operator or patient.
- When unloading the stretcher from the patient compartment, ensure that the caster wheels are safely set on the ground or damage to the product may occur.
- Wheel lock(s) are only intended to help prevent the stretcher from rolling while unattended and to aid in patient transfer. A wheel lock may not provide sufficient resistance on all surfaces or under loads.
- Ensure that the restraints are not entangled in the base frame when raising and lowering the stretcher.
- Do not store items under the stretcher mattress. Storing items under the mattress can interfere with the operation of the stretcher.
- Do not steam clean or ultrasonically clean the unit.
- Maximum water temperature should not exceed 80°C.
- Allow stretcher to air dry.
- Towel dry all casters and interface points.
- Failure to comply with these instructions may invalidate any/all warranties.
- Improper maintenance can cause injury or damage to the product. Maintain the stretcher as described in this manual. Use only Kartsana approved parts and maintenance procedures. Using unapproved parts and procedures could cause unpredictable operation and/or injury and will void the product warranty
- Failure to use authorized parts, lubricants, etc. could cause damage to the stretcher and will void the warranty of the product.

NOTES:



- Loose items or debris on the patient compartment floor can interfere with the operation of the safety hook and stretcher fastener. Keep the patient compartment floor clear
- This manual should be considered a permanent part of the stretcher and should remain with the product even if the stretcher is subsequently sold.
- Kartsana continually seeks advancements in product design and quality. Therefore, while this manual contains the most current product information available at the time of printing, there may be minor discrepancies between your stretcher and this manual
- Kartsana recommends that, prior to installation, the certified mechanic plan the placement of the safety hook in the rear of the vehicle.

2.- INSTRUCTIONS MANUAL

TGE-241 series is adapted for mounting on Kartsana rails R-419, R-450-S inox, R-800 and R-900



To reduce the risk of injuries to the patient and accompanying persons in the event of an accident, it is advisable to avoid sharp edges and projecting parts inside the ambulance, paying special attention to the areas nearest to the stretcher.

Make sure that no damage is caused to the areas containing the stretcher mechanisms, to prevent them from malfunctioning.

2.1.- Technical specifications

2.1.1.- Technical specifications TGE-241-M / XL

Measurements (in mm):

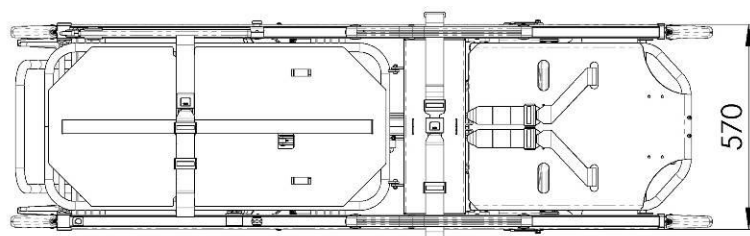
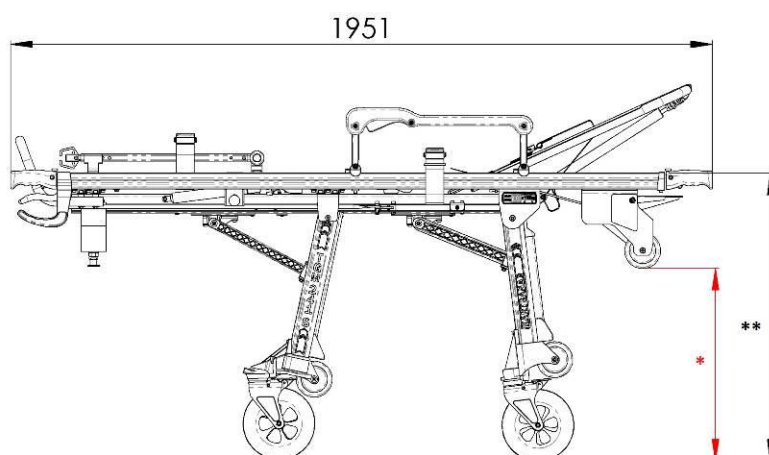

MODEL	*	**
TGE-241-M	536	800
TGE-241-XL	635	900

2.2.- Operating and handling the stretcher



To prevent injuries to limbs and other body parts, make sure they are not within the range of the moving parts of the stretcher.

Clarification: The front part of the stretcher corresponds to the head part.

2.2.1.- Removable cuffs

Press the button at the top of the cuff, and then pull it to lengthen the cuff, as far as it will go.

To return the cuff to its original position, press the top button again and push it as far as it will go in the original position

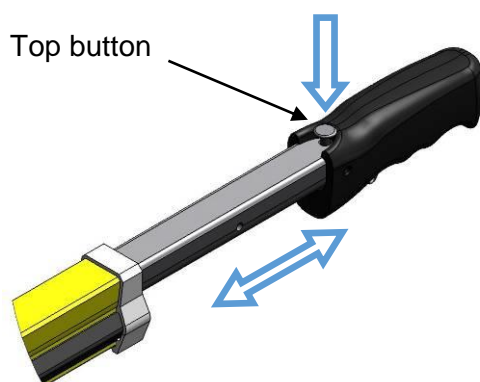

The top adhesive on the part of the stretcher shown in the drawing on the left indicates how to manipulate the cuff in order to extend it.

2.2.2.- Adjustable reclining head

Apply the lever below the head and move it to the required position. Then release the lever so that the head is locked in the required position.

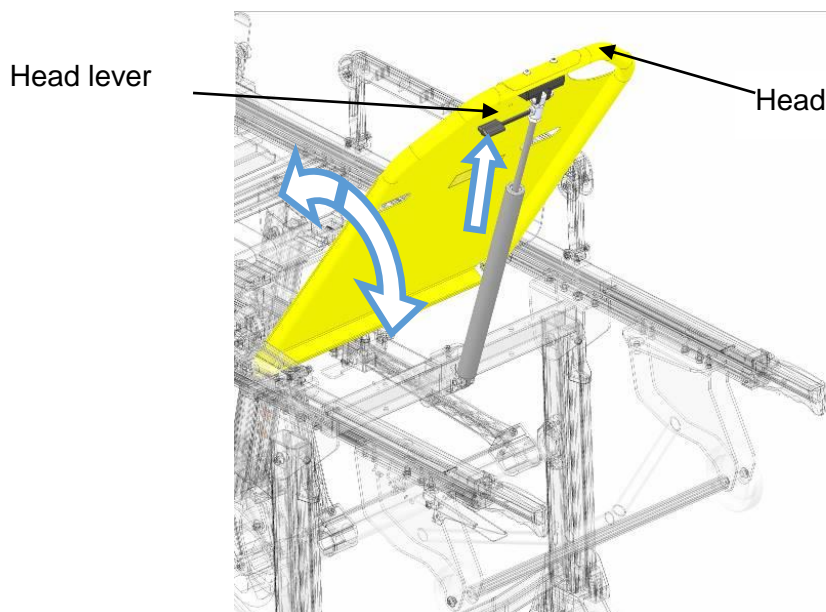

2.2.3.- Safety rail

The safety rail has a red bar that locks the rail into place. To lower the rail, just press the bar as shown in the figure below. To lock it in the safety position again, move it to that position manually, and it will automatically lock into place.

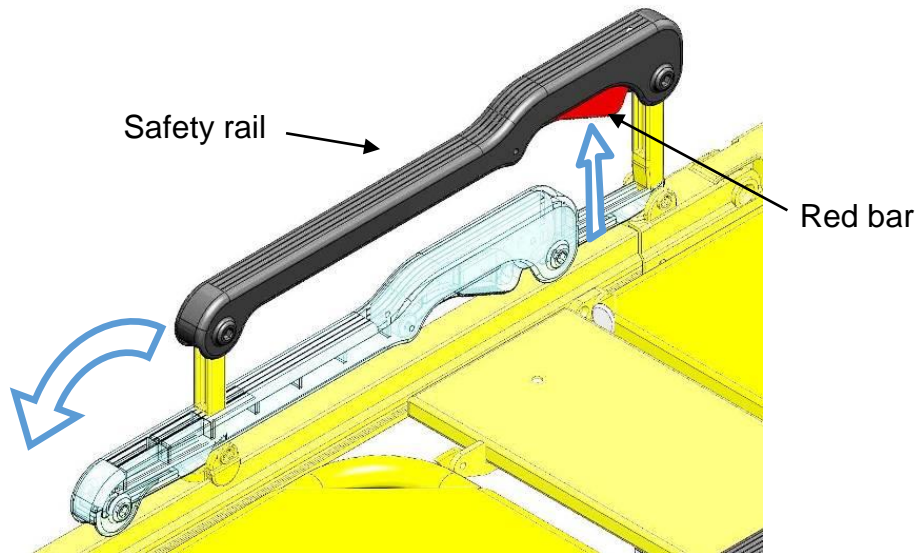

2.2.4.- Intravenous drip stand

The stretcher comes with a drip holder located on the left hand side.



With the “A” knob we can loosen and tighten the assembly where and when it is convenient. Unscrewing the knob “B” we remove the IV drip stand to the vertical position perpendicular to the stretcher, then we twist the knob again.

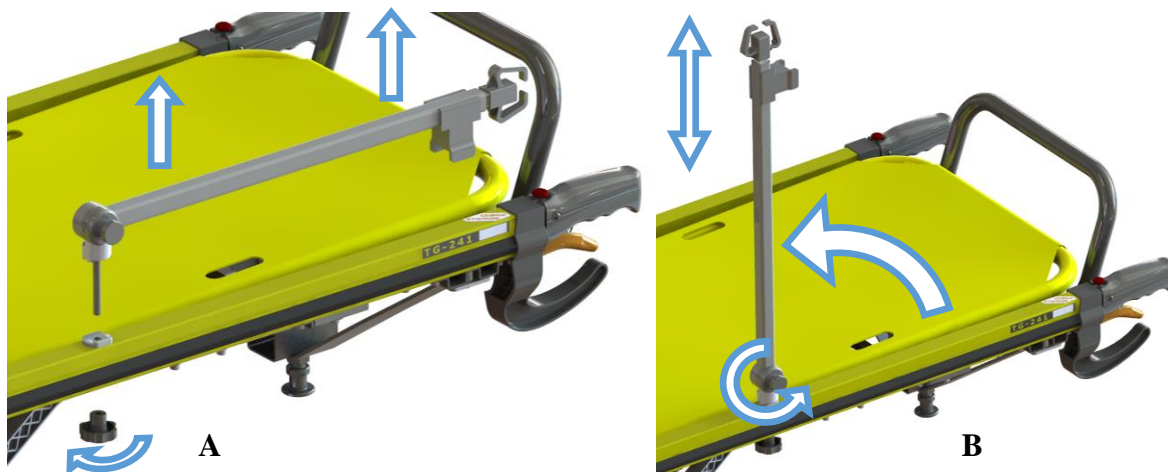

The length of said drip pole may be lengthened or shortened pressing a small positioner located on the inner side, raising the hook until the upper position is reached.



The maximum load allowed for the drip pole is 6 Kg.

The maximum weight is indicated on the drip rod by an adhesive like the one shown above.

PESO MÁXIMO: 6 Kg
MAXIMUM LOAD:

2.2.5.- Method for fastening the safety belts on the patient's head and feet

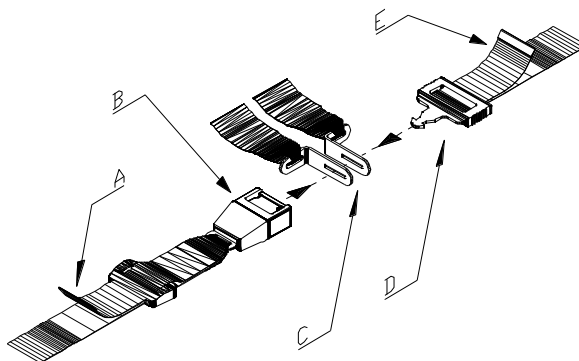

Place the clasps (C) in the position shown in the figure above. Pass the male part of the buckle (D) between the openings (C) until it is inserted into the female part B. Once the assembly is anchored in place, centre and tauten the assembly, adjusting the tension of the belt at ends A and/or E. **NOTE:** The foot belt is not fitted with the C openings.

2.2.6.- Method for fastening the safety belt on the patient's

It is advisable for this belt to be attached to the stretcher to ensure the complete safety of the patients and guarantee compliance with the UNE-EN 1865 standard test that is performed.



Put the female part of the buckle A and male part B in the position shown in the figure below and insert the latter into the slot in the former. Once the assembly is firmly secured, centre and tauten it, adjusting the tension of the belt at end C.

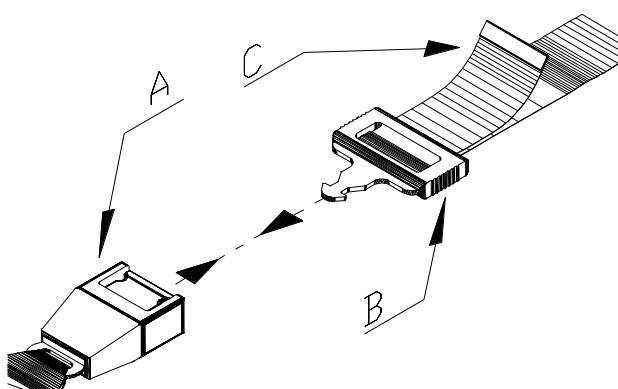

It is advisable to ensure that while the patient is on the stretcher, he/she is secured at all times by the safety belts.

2.2.7.- Dismantling-assembling the stretcher safety belts

- Anchoring with a knot

To dismantle the belts, pass the belt through the slot in the buckle as shown in the following figure. To assembly it, just follow the same process but in reverse order.

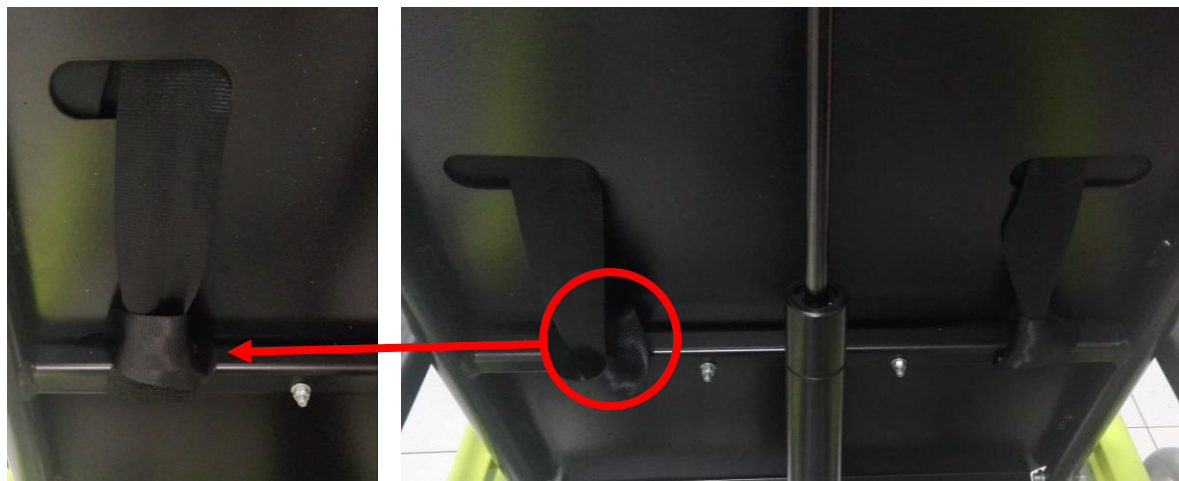

The lateral belts must be fixed on the lateral profiles of the stretcher with a knot also.



2.2.7.1.- Position of the belts

2.2.7.1.1.- Lateral belts

The belts are positioned at the approximate distances shown in the figure below:

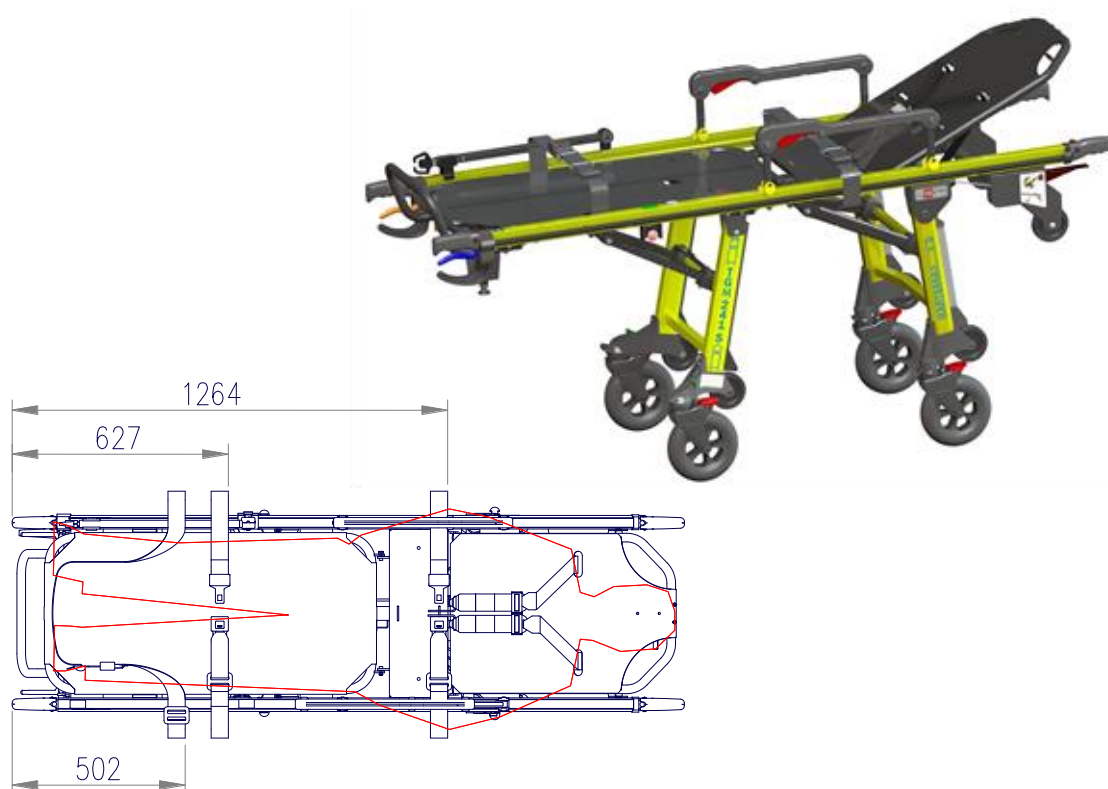

2.2.7.1.2.- Head belts

The belts must be passed through the holes in the head rest part and secured on the crosspiece of the panel with a knot.

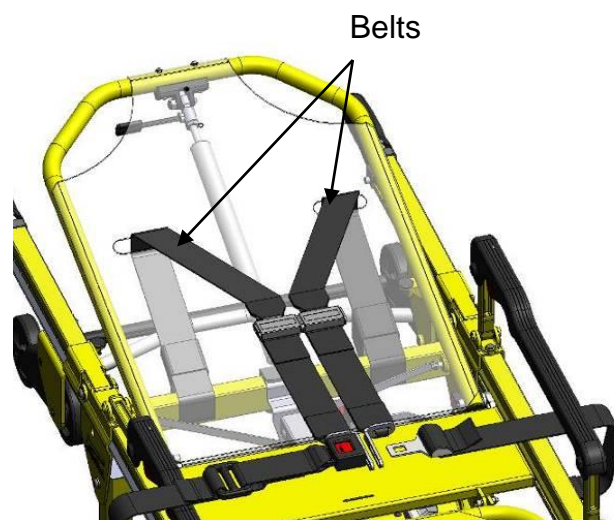

2.2.8.- Control for operating the stretcher legs

2.2.8.1.-Rear controls

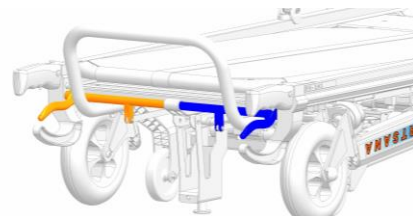

- Blue (right): Folds/unfolds the front leg of the stretcher.

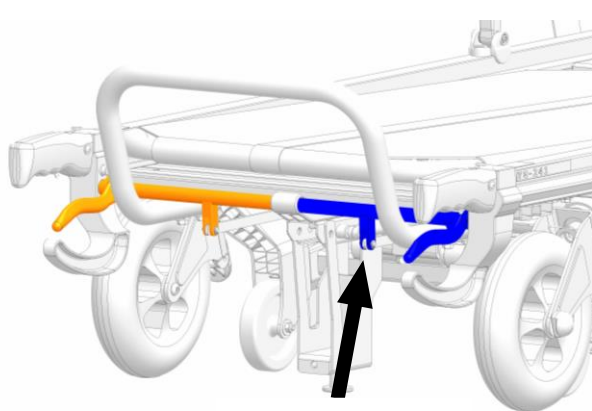

Blue lever

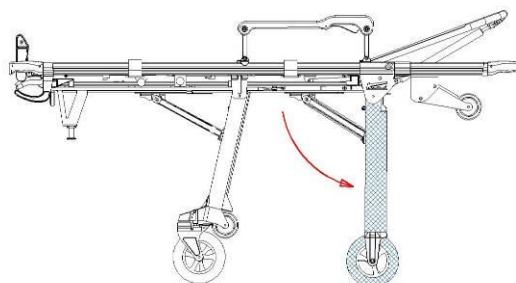

- Orange (left): Folds/unfolds or activates the intermediate position of the rear leg of the stretcher.

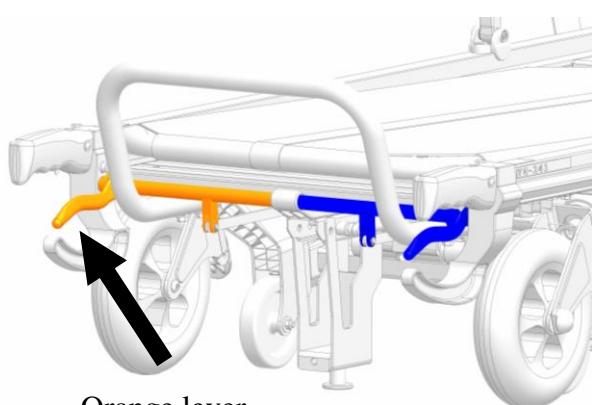

Orange lever

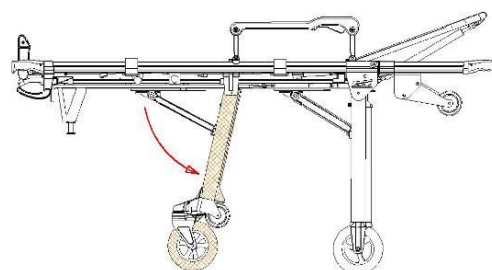

Note: If the cart is to be folded, release the control just before the leg reaches the fully folded position. To activate the intermediate positions, release the control when the leg starts to move. If the intermediate position is not correct, apply the control again until the leg is locked in the correct position. Every time the leg is activated, check it is locked by the click that guarantees this

2.2.8.2.- Lever front leg control

It activates the intermediate positions of the front leg of the stretcher (the starting point is the unfolded position).

Note: To return the leg to its original unfolded position, activate the front control and then raise that part of the stretcher manually so that the leg returns automatically. Just before the leg reaches the original unfolded position, release the control so that when the leg reaches that position, the click can be heard, indicating the leg is locked and thereby ensuring it is fixed in the original unfolded position.

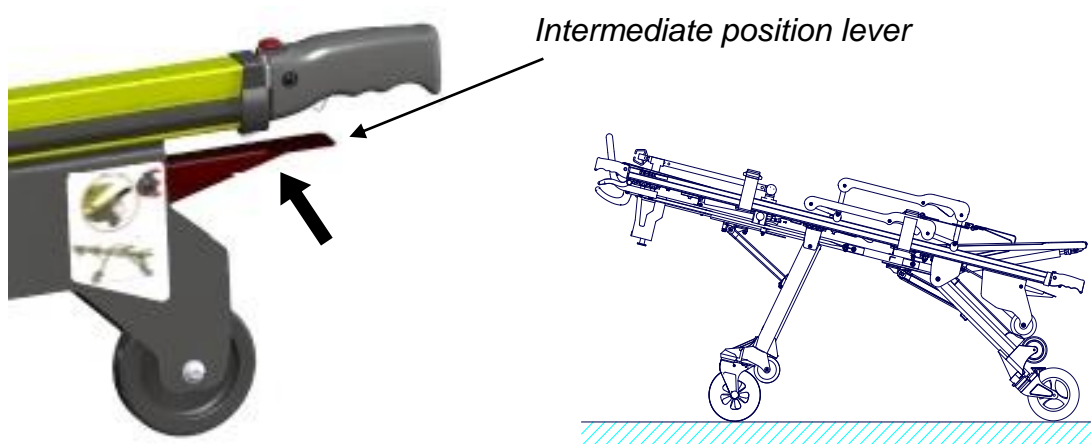

2.2.9.- Intermediate positions of the stretcher



The stretcher has three kind of intermediate positions at different heights from the ground, depending on each need.

To ensure the safe treatment of the patient, two people should always activate the intermediate position. In addition, the safety belts must be placed on the patient and the rails raised before activating the intermediate positions.

1st Intermediate position:



Hold the stretcher firmly with both hands to prevent it from making dangerous movements.

Then the stretcher can also be inclined on one part (front or rear) by activating the controls as described above.

To perform this manoeuvre, activate the brakes on the front wheels and place them in the position shown on the adhesive, before activating the red lever at the side.



The position is achieved by activating the intermediate position lever (red) located on the right-hand side of the stretcher. This releases the front legs up to a mechanical stop.

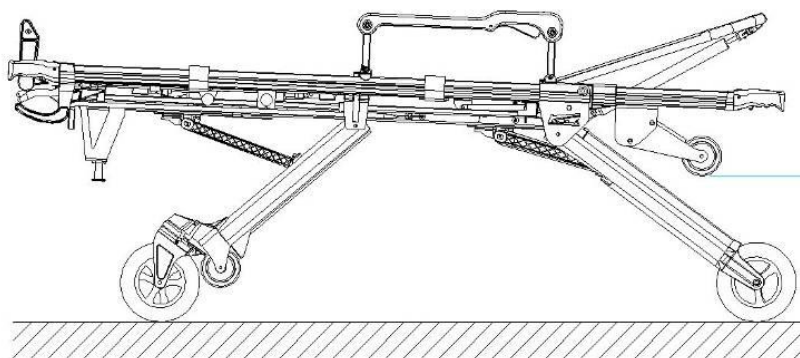

Then apply the rear control (orange) once until it reaches the first position.

To return to the unfolded leg position, lift the stretcher slightly and raise the front legs using your foot.

2nd Trendelenburg position



To perform this manoeuvre, activate the brakes on the front wheels and place them in the position shown on the adhesive, before activating the red lever at the side.



It is achieved by activating the intermediate position lever (red) located on the right-hand side of the stretcher. This releases the front legs up to a mechanical stop.

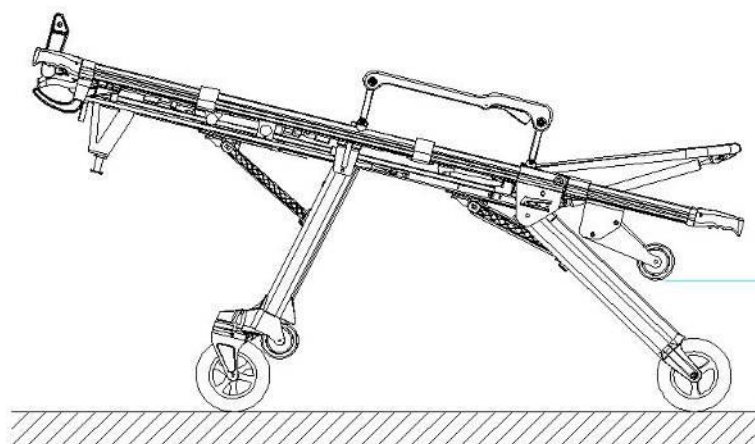

3rd Contratrendelenburg position

It is positioned by activating the rear control (orange) once until it reaches the first position.

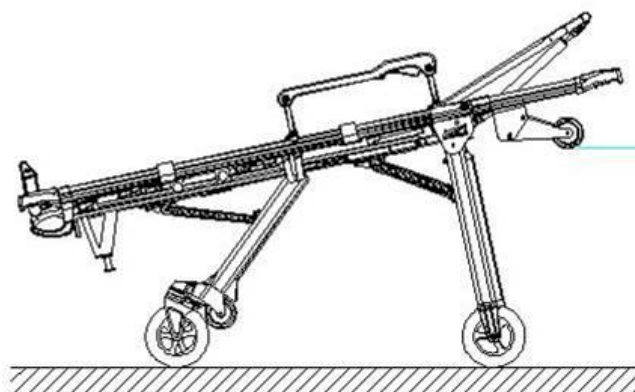

2.2.10.- Brake lever

Activate the red lever with your foot to enable the brake to lock the rear wheels. That special brake blocks both the longitudinal and the rotating movement of the stretcher.

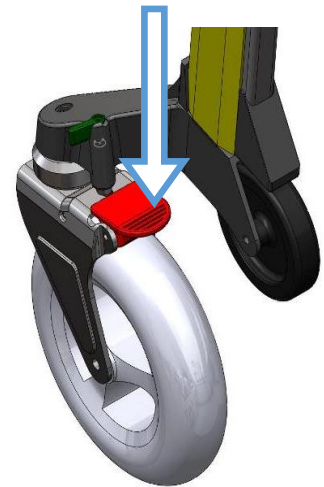

2.2.11.- Lock/Unlock wheels

- Rear wheels

The green bolt is used to block or unblock the rotation of the wheels, as shown in the following figure.

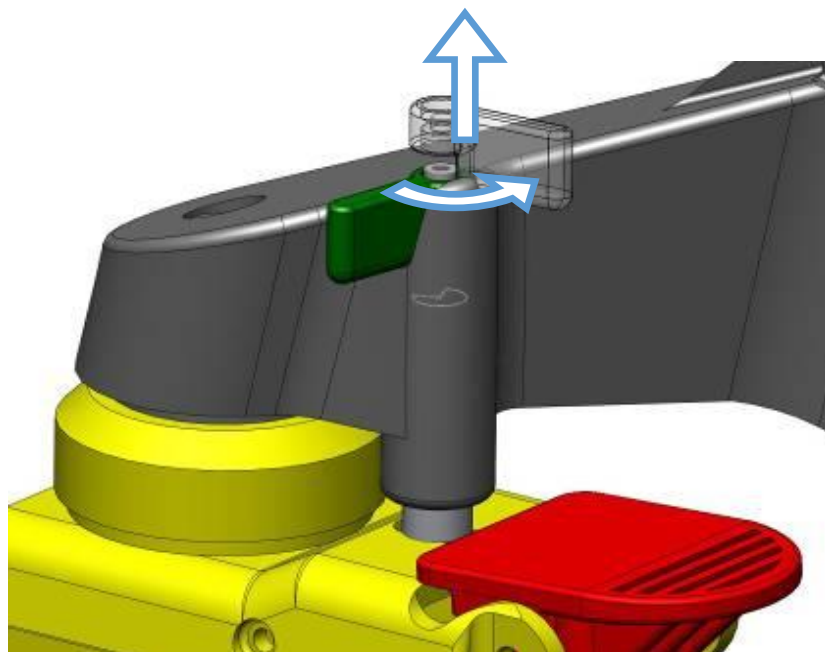

2.2.12.- Mounting the stretcher on the ambulance stretcher holder

Kartsana recommends using the Kartsana rails to secure the stretcher to the ambulance, since these have been specially designed for that purpose



Guide the stretcher to the ambulance platform and mount its front wheels (wheels with a diameter of 100 mm), on the stretcher holder, and if the platform has a Kartsana rail, place the front wheels outside the rails. Then activate the front wheels control to fold the front leg (blue control) and insert the stretcher into the stretcher holder up to the rear wheels. At this point, activate the rear wheel control (orange) to fold it.

After activating the orange control, part of the weight of the rear end of the stretcher must be supported, and so it will be necessary to hold it firmly with both hands.

Once the above process has been executed in full, the stretcher can be inserted completely into the stretcher holder, until it is locked in place at the front and rear. The Kartsana rails anchors the stretcher at the front by means of two anchoring points and one anchoring point at the rear (see the figures below). These anchoring points prevent the stretcher from overturning in the event of an accident. In the event of not using the Kartsana rails, it is advisable that the front part of the stretcher cart be anchored at the end of the bar marked 12 in the exploded diagram of the cart that is included in this manual

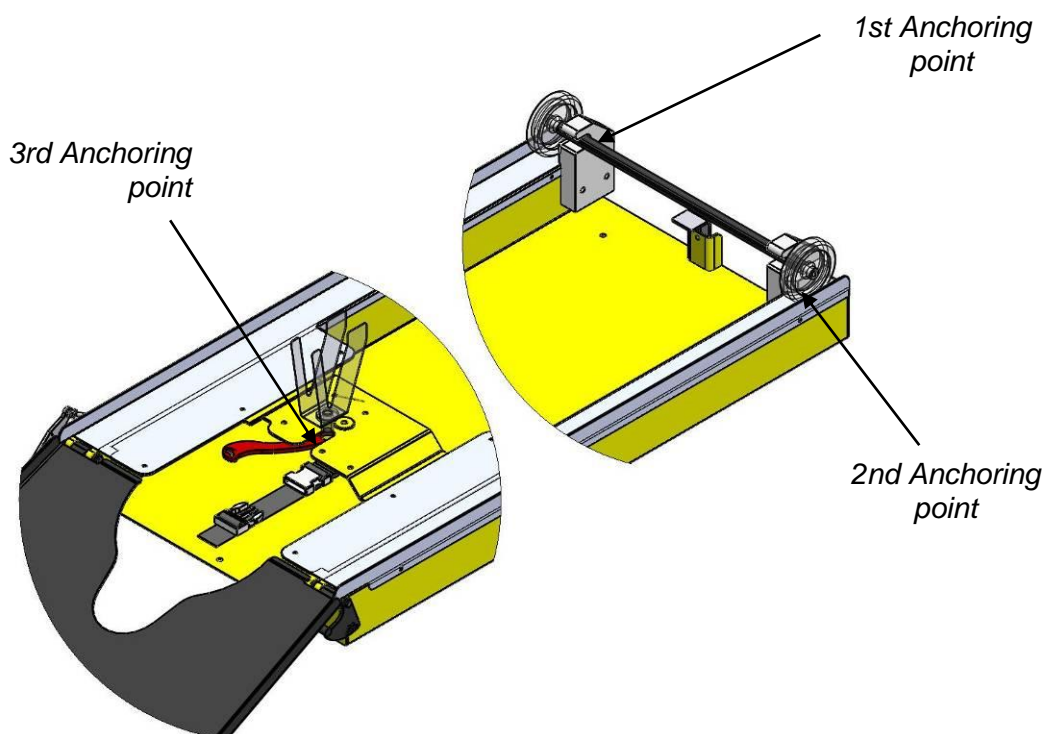

3.- DESINFECTION

When disinfecting the stretcher, use products that will not damage the surface of the materials and wipe with a cloth or something similar. If the surface to be disinfected is greased, regreased it after disinfecting it.

All disinfectants must be used in accordance with the manufacturer's instructions.

The manufacturer will not be held responsible for any anomaly or damage caused by using a cleaning product that could damage the surface of the rail materials.

To ensure the hygiene and proper conservation of the product components, the manufacturer recommends that they be disinfected after each use.

4.- MAINTENANCE

Check and grease the interior of the leg guide every six months.

In addition, check and grease the stretcher wheels and the locking systems. We recommend that a specialist from our company perform maintenance every six months. During this inspection, a general check will be made to replace any parts that could be damaged or worn due to use.

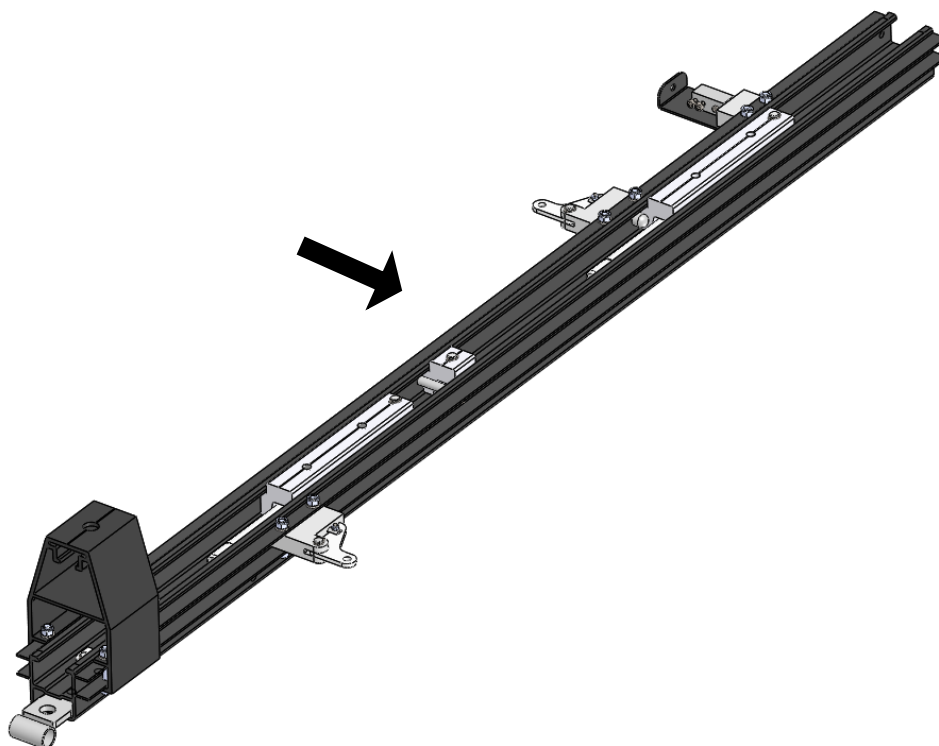

5.- EXPLODED VIEWS

5.1.- TGE-241-M

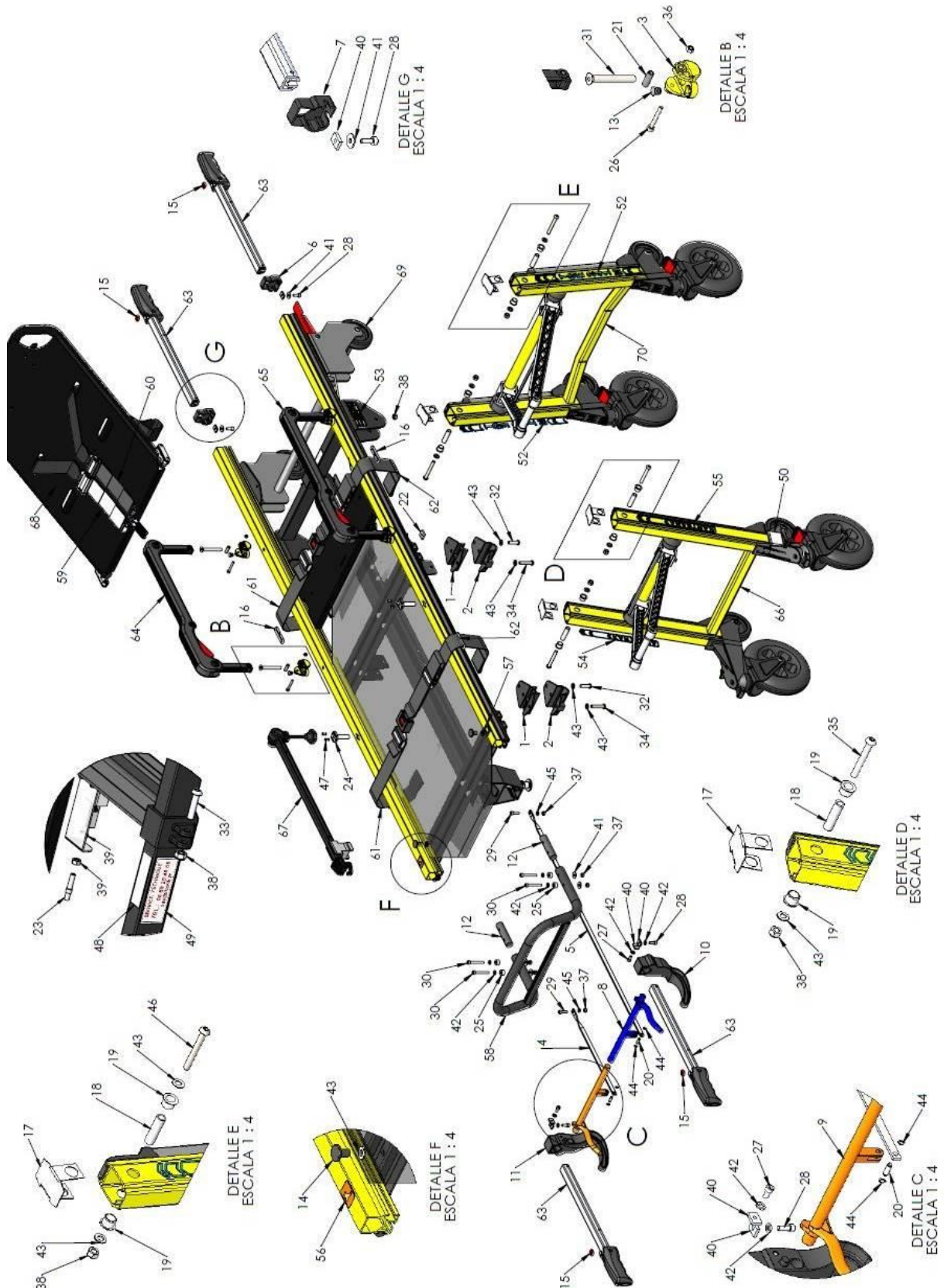



acondicionamiento para hospitales y ambulancias

OPERATION AND HANDLING OF THE TGE-241 SERIES

Nº	REFERENCIA	DESCRIPCIÓN	CANT.
1	01-0130-001	BRIDA MACHO PATA 860-400	2
2	01-0131-001	BRIDA HEMBRA PATA 860-400	2
3	01-0159-001	SUJECCION BARANDILLA FUEGO	4
4	03-1069-001	TIRADOR GATILLO PATA TRASERA FUEGO	1
5	03-1073-001	TIRADOR GATILLO PATA DELANTERA TG-241	1
6	05-0050-001	PROCTE.PERFIL GOMA IZQUIERDO	1
7	05-0051-001	PROCTE.PERFIL GOMA DERECHO	1
8	05-0105-001	GATILLO AZUL S-FUEGO	1
9	05-0106-001	GATILLO NARANJA S-FUEGO	1
10	05-0107-001	PROTECTOR GATILLOS DCH S-FUEGO	1
11	05-0108-001	PROTECTOR GATILLOS IZQ S-FUEGO	1
12	05-0331-001	MACIZO NYLON INT. POSAPIES TG-241	2
13	06-0006-001	TAPONES D12. R26	4
14	06-0013-001	TAPONES TOPE CABEZAL R-56 D22	2
15	08-0009-001	GOMA SETA DE PUÑOS NUEVOS	4
16	09-0027-001	ANILLA PASANTE CINTURON	4
17	11-0060-001	TAPA CHAPA PARA PATA	4
18	12-0074-002	CASQUILLO COJINETE GIRO PATA 230	4
19	12-0077-002	CASQUILLO TOPE PATA	8
20	12-0123-001	EJE ANILLO GATILLO GAMA 4	2
21	12-0178-001	CASQUILLO BARANDILLA S-FUEGO	4
22	12-0180-001	TUERCA CUADRADA	2
23	12-0333-002	TOPE 2 PARA FUNDA CABLE	1
24	12-0469-002	SOPORTE POSICIONADOR PALO DE SUERO STANDARD	2
25	12-0495-001	DISTANCIAL $\varnothing 14 \times \varnothing 6.25 \times 7$ PIERNAZAL TG-241	4
26	13-0016-001	ALLEN DIN 912 M5X35 - 8.8 CINCADO	4
27	13-0020-001	ALLEN DIN 912 M6X12 - 8.8 CINCADO	2
28	13-0023-001	ALLEN DIN 912 M6X16 - 8.8 CINCADO	4
29	13-0024-001	ALLEN DIN 912 M6X20 - 8.8 CINCADO	2
30	13-0030-001	ALLEN DIN 912 M6X45 - 8.8 CINCADO	4
31	13-0085-001	AVELLANADO ALLEN DIN 7991 - M8 x 65 CINCADO	4
32	13-0115-001	DIN 7380 ULS M8x30 -10.9 CINCADO	2
33	13-0116-001	DIN 7380 ULS M8x35 -10.9 CINCADO	1
34	13-0117-001	DIN 7380 ULS M8x40 -10.9 CINCADO	2



acondicionamiento para hospitales y ambulancias

OPERATION AND HANDLING OF THE TGE-241 SERIES

Nº	REFERENCIA	DESCRIPCIÓN	CANT.
35	13-0121-001	DIN 7380 ULS M8x60 -10.9 CINCADO	2
36	13-0176-001	TUERCA AUTOBLOCANTE M5	4
37	13-0177-001	TUERCA AUTOBLOCANTE M6	6
38	13-0178-001	TUERCA AUTOBLOCANTE M8	7
39	13-0191-001	TUERCA HEXAGONAL M6 CINCADA	2
40	13-0193-001	TUERCA RECTANGULAR M6	6
41	13-0202-001	ARANDELA ANCHA d6 CINCADA	6
42	13-0207-001	ARANDELA d6 CINCADA	8
43	13-0208-001	ARANDELA d8 CINCADA	12
44	13-0214-001	RETAINING RING FOR SHAFTS EXT. ø6	4
45	13-0220-001	ARANDELA NYLON d.6	2
46	13-0276-001	DIN 7380 ULS M8x65 -10.9 CINCADO	2
47	13-0318-001	REMACHE DE ACERO INOX. 4X12	4
48	14-0030-001	ETIQUETA SERIE	2
49	14-0141-002	ETIQUETA SERVICE TECHNIQUE IBERIK	1
50	14-0181-001	ETIQUETA SIEMPRE LENGUETA VERDE IZQ. TG-241	1
51	14-0184-001	ETIQUETA SIEMPRE LENGUETA VERDE DER. TG-241	1
52	14-0239-001	ETIQUETA TGE-241M	2
53	14-0310-001	ETIQUETA PESO MAX. 250 Kg. SERIE 241	2
54	14-0247-001	ETIQUETA DER. KARTSANA FLECHAS PATA TRASERA TG-241	1
55	14-0248-001	ETIQUETA IZQ. KARTSANA FLECHAS PATA TRASERA TG-241	1
56	14-0249-001	ETIQUETA PLEGAR PATAS PIES	1
57	14-0250-001	ETIQUETAS PLEGAR PATAS CABEZA	1
58	50-0510-001	CJTO. SOLDADO POSAPIES TG-241	1
59	52-0047-001	fromparent+CJTO. CINTURON CABEZAL DCH.	1
60	52-0048-001	CJTO. CINTURON CABEZAL DCH.	1
61	52-0053-001	PREMON. CINTURÓN LARGO NEGRO S.116-400	2
62	52-0054-001	PREMONTAJE CINTURON CORTO	2
63	52-0357-002	PREMONTAJE PUÑO CAMILLA 116-400	4
64	52-0421-001	BARANDILLA IZQUIERDA S-FUEGO	1
65	52-0422-001	BARANDILLA DERECHA S-FUEGO	1
66	52-0536-003	PATA GIR. TRAS. TG-241, TG-241G, TG(E)-241M, FUEGO	1
67	52-0610-001	MTJE. SOPORTE DE SUERO STANDARD	1
68	52-0693-00A	PREMONTAJE CABEZAL SERIE 241	1
69	52-0725-00A	CUADRO COMPLETO TGE-241 M	1
70	52-0741-001	PATA GIR. DEL. TGE-241M	1

5.2.- TGE-241-XL

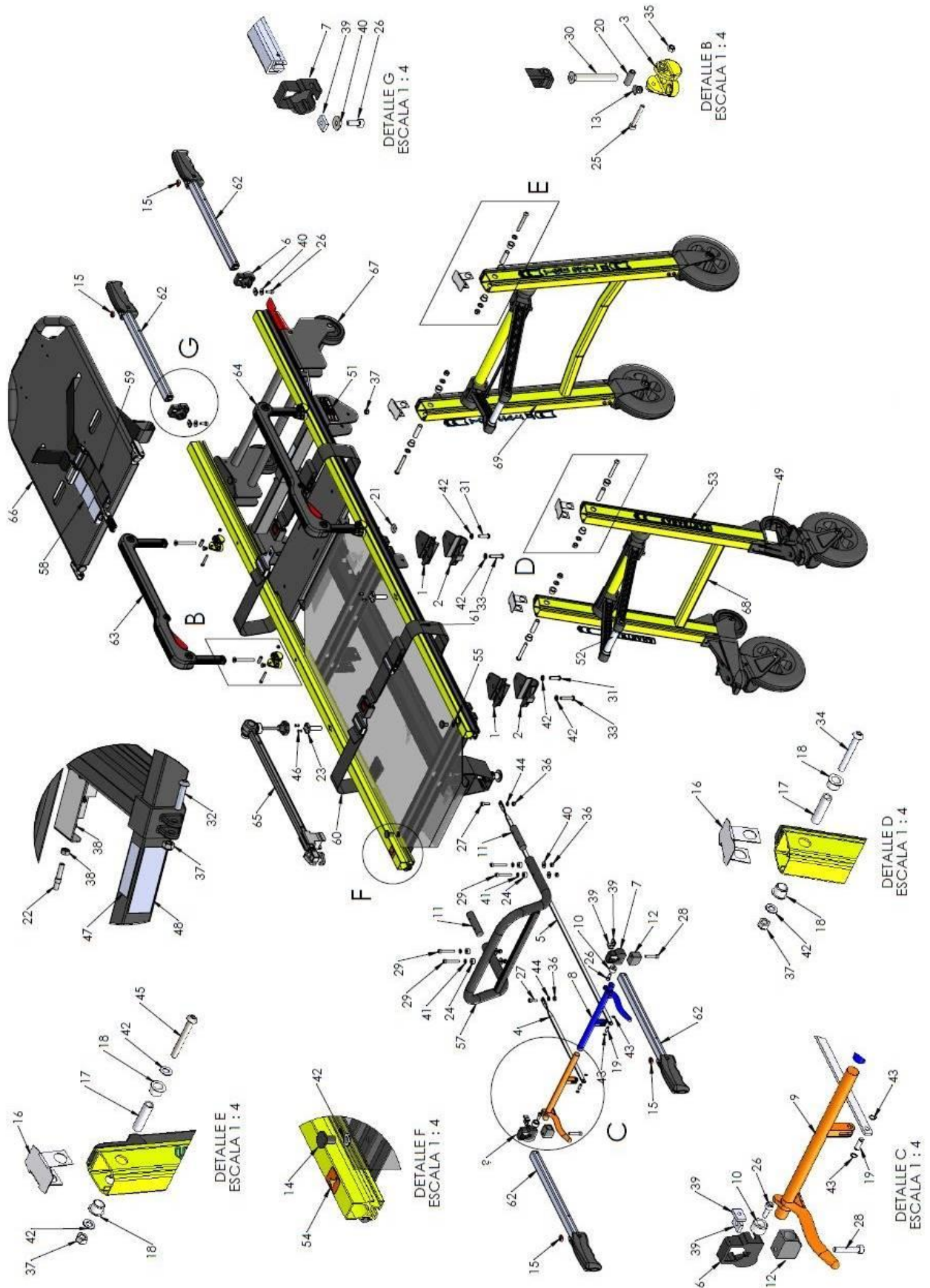

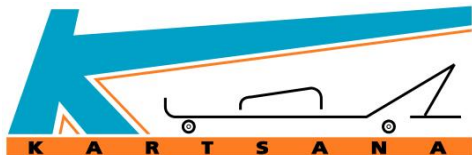

acondicionamiento para hospitales y ambulancias

OPERATION AND HANDLING OF THE TGE-241 SERIES

Nº	REFERENCIA	DESCRIPCIÓN	CANT.
1	01-0130-001	BRIDA MACHO PATA 860-400	2
2	01-0131-001	BRIDA HEMBRA PATA 860-400	2
3	01-0159-001	SUJECCION BARANDILLA FUEGO	4
4	03-1069-001	TIRADOR GATILLO PATA TRASERA FUEGO	1
5	03-1073-001	TIRADOR GATILLO PATA DELANTERA TG-241	1
6	05-0050-001	PROCTE.PERFIL GOMA IZQUIERDO	2
7	05-0051-001	PROCTE.PERFIL GOMA DERECHO	2
8	05-0105-001	GATILLO AZUL S-FUEGO	1
9	05-0106-001	GATILLO NARANJA S-FUEGO	1
10	05-0214-001	TOPE POSICIÓN PLEGADA BRAVA	2
11	05-0331-001	MACIZO NYLON INT. POSAPIES TG-241	2
12	05-0390-003	CENTRAL SUJECION GATILLOS.241 IRAK	2
13	06-0006-001	TAPONES D12. R26	4
14	06-0013-001	TAPONES TOPE CABEZAL R-56 D22	2
15	08-0009-001	GOMA SETA DE PUÑOS NUEVOS	4
16	11-0060-001	TAPA CHAPA PARA PATA	4
17	12-0074-002	CASQUILLO COJINETE GIRO PATA 230	4
18	12-0077-002	CASQUILLO TOPE PATA	8
19	12-0123-001	EJE ANILLO GATILLO GAMA 4	2
20	12-0178-001	CASQUILLO BARANDILLA S-FUEGO	4
21	12-0180-001	TUERCA CUADRADA	2
22	12-0333-002	TOPE 2 PARA FUNDA CABLE	1
23	12-0469-002	SOPORTE POSICIONADOR PALO DE SUERO STANDARD	2
24	12-0495-001	DISTANCIAL $\varnothing 14 \times \varnothing 6.25 \times 7$ PIERNAZAL TG-241	4
25	13-0016-001	ALLEN DIN 912 M5X35 - 8.8 CINCADO	4
26	13-0023-001	ALLEN DIN 912 M6X16 - 8.8 CINCADO	4
27	13-0024-001	ALLEN DIN 912 M6X20 - 8.8 CINCADO	2
28	13-0028-001	ALLEN DIN 912 M6X35 - 8.8 CINCADO	2
29	13-0030-001	ALLEN DIN 912 M6X45 - 8.8 CINCADO	4
30	13-0085-001	AVELLANADO ALLEN DIN 7991 - M8 x 65 CINCADO	4
31	13-0115-001	DIN 7380 ULS M8x30 -10.9 CINCADO	2
32	13-0116-001	DIN 7380 ULS M8x35 -10.9 CINCADO	1
33	13-0117-001	DIN 7380 ULS M8x40 -10.9 CINCADO	2
34	13-0121-001	DIN 7380 ULS M8x60 -10.9 CINCADO	2



acondicionamiento para hospitales y ambulancias

OPERATION AND HANDLING OF THE TGE-241 SERIES

Nº	REFERENCIA	DESCRIPCIÓN	CANT.
35	13-0176-001	TUERCA AUTOBLOCANTE M5	4
36	13-0177-001	TUERCA AUTOBLOCANTE M6	6
37	13-0178-001	TUERCA AUTOBLOCANTE M8	7
38	13-0191-001	TUERCA HEXAGONAL M6 CINCADA	2
39	13-0193-001	TUERCA RECTANGULAR M6	6
40	13-0202-001	ARANDELA ANCHA d6 CINCADA	6
41	13-0207-001	ARANDELA d6 CINCADA	4
42	13-0208-001	ARANDELA d8 CINCADA	12
43	13-0214-001	RETAINING RING FOR SHAFTS EXT. ø6	4
44	13-0220-001	ARANDELA NYLON d.6	2
45	13-0276-001	DIN 7380 ULS M8x65 -10.9 CINCADO	2
46	13-0318-001	REMACHE DE ACERO INOX. 4X12	4
47	14-0030-001	ETIQUETA SERIE	2
48	14-0141-002	ETIQUETA SERVICE TECHNIQUE IBERIK	1
49	14-0181-001	ETIQUETA SIEMPRE LENGUETA VERDE IZQ. TG-241	1
50	14-0184-001	ETIQUETA SIEMPRE LENGUETA VERDE DER. TG-241	1
51	14-0243-002	ETIQUETA CARGA MAXIMA 190kg	2
52	14-0247-001	ETIQUETA DER. KARTSANA FLECHAS PATA TRASERA TG-241	1
53	14-0248-001	ETIQUETA IZQ. KARTSANA FLECHAS PATA TRASERA TG-241	1
54	14-0249-001	ETIQUETA PLEGAR PATAS PIES	1
55	14-0250-001	ETIQUETAS PLEGAR PATAS CABEZA	1
56	14-0310-001	ETIQUETA PESO MAX. 250 Kg. SERIE 241	2
57	50-0510-001	CJTO. SOLDADO POSAPIES TG-241	1
58	52-0047-001	CJTO. CINTURON CABEZAL DCH.	1
59	52-0048-001	CJTO. CINTURON CABEZAL DCH.	1
60	52-0053-001	PREMON. CINTURÓN LARGO NEGRO S.116-400	2
61	52-0054-001	PREMONTAJE CINTURON CORTO	2
62	52-0357-002	PREMONTAJE PUÑO CAMILLA 116-400	4
63	52-0421-001	BARANDILLA IZQUIERDA S-FUEGO	1
64	52-0422-001	BARANDILLA DERECHA S-FUEGO	1
65	52-0610-001	MTJE. SOPORTE DE SUERO STANDARD	1
66	52-0693-00A	PREMONTAJE CABEZAL SERIE 241	1
67	52-0725-00A	CUADRO COMPLETO TGE-241 M	1
68	52-0735-00A	PATA GIRATORIA TRASERA XL (TGE-241 XL)	1
69	52-0736-00A	PATA FIJA DELANTERA XL (TGE-241 XL)	1

- i. The pieces that his number reference starts in 13-xxxx-xxx will be elements of fixation.
- ii. The pieces that his number reference starts in 50-xxxx-xxx will be welding sets and it will be supplied like an inseparable set, not at loose parts.
- iii. The pieces that his number reference starts in 52-xxxx-xxx will be preassembly. In case of requesting some piece that belongs to a preassembly, contact with our technical services taking the reference of this preassembly and, if it's necessary, the exploded view of preassembly may be provided.



KARTSANA S.L.
Narcis Monturiol, 34
08192 Sant Quirze del Vallès
Barcelona (España)
Tel.: + 34 937 158 672 ext.-4
www.kartsana.com



IBERIK
31, Rue de l'Industrie
Batiment Eole · ZI des Joncaux
64700 Hendaye · Francia
Tel.: + 33(0) 559 204 965
iberik@iberik.com
www.iberik.fr

Technical Service
sat@kartsana.com



*Sistema de gestión
certificado*

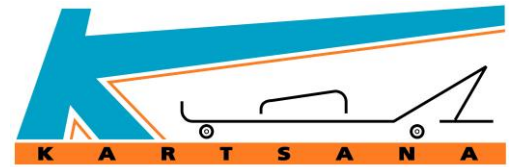

acondicionamiento para hospitales y ambulancias